



Dual Induction / Contact Welders

Thermatool Dual Induction / Contact Welders offer the following features and benefits:

- Two processes in one welding system.
- Available from 350 kW to 1200 kW output.
- Quick Change capability - Switch between Induction / Contact via Selector Switch on Operator's Console. Contact / Coil modules simplify changeover process.
- Meet demanding API pipe specifications with the induction process.
- Achieve highest power cost savings with the contact weld process.
- Achieve highest efficiency when welding hollow structural sections (HSS) or other products.

With ever increasing energy costs worldwide, more large diameter pipe producers have been selecting Thermatool's new Dual Induction / Contact Welders. This gives the producer the ability to realise significant power cost savings when welding larger diameters with the more efficient contact welding process.

Thermatool, the original inventor of the HF contact welding process, has met the evolving requirements of API pipe production with Solid-State Induction Welders. With recent advances in power supply design, Thermatool has taken the best of both welding processes and combined them in one welding system.

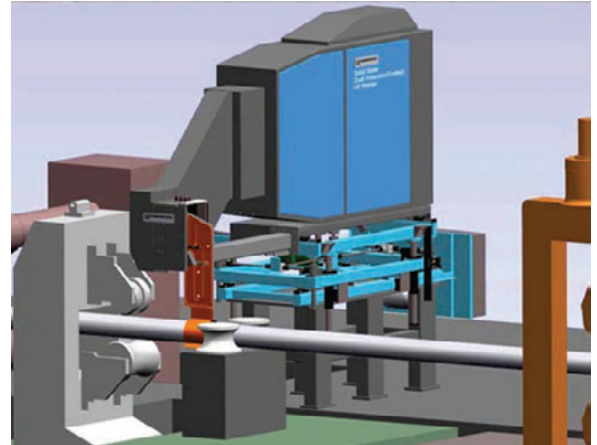

For more information, call: +44 (0) 1256 335533, email: info@ihwtech.co.uk or visit www.inductotherm-hwt.co.uk



Dual Induction / Contact Solid-State Welder with Three Axis Table

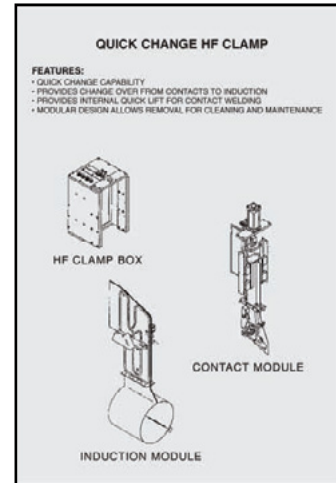
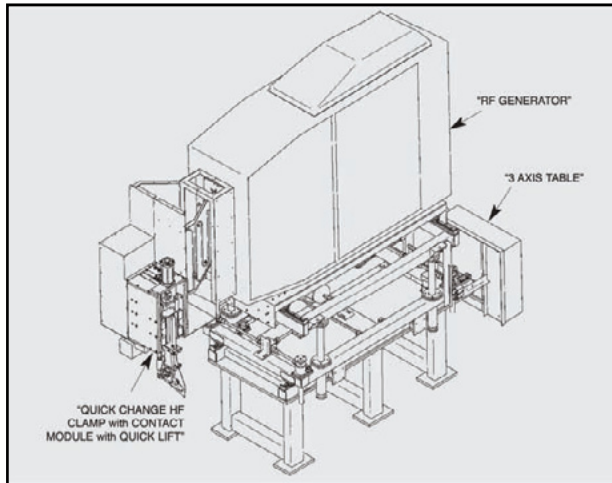

Induction Welding vs Contact Welding

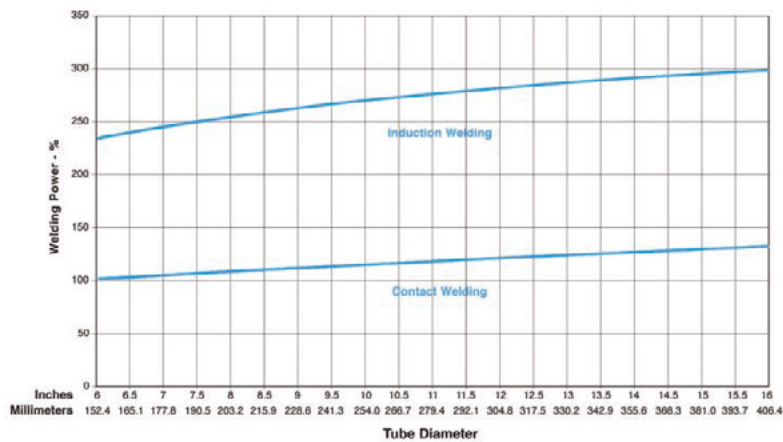

Note: Welding Power is for 0.5 Inch (12.5mm) Wall Pipe welded at 90 Feet per Minute (27mpm).

Inductotherm Heating & Welding Technologies Ltd
Thermatool House, Crockford Lane, Basingstoke, RG24 8NA

Tel: +44 (0) 1256 335533 Fax: +44 (0) 1256 467224

Email: info@ohwtech.co.uk

www.inductotherm-hwt.co.uk

